

TSH - P1 INSTRUCTION MANUAL

The TENTEL TSH-P1 reference plane gauge allows several critical measurements to be made on DVCPRO tape transports. This reference plane gauge and accompanying 'plane height post', 'guide height bar', and 'reel table height indicator' replace Panasonic part numbers VFK 1153, 1154 and 1157. The TSH-P1 also allows accurate measurement of the reel table heights and the perpendicularity of the reel tables.

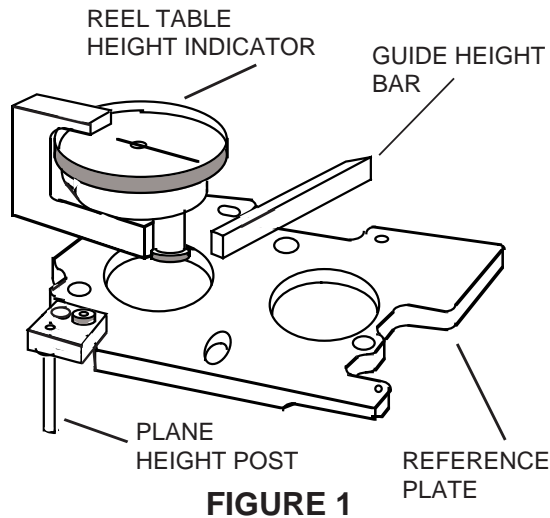

Place a medium (M) size cassette into the transport to move the reels and switches into the proper position. Follow the instructions in the Panasonic Manual for use of their VFK 1153, 1154, and 1157; the TSH-P1 will substitute for each of the measurements shown in the 'factory' manual.

Guide height set-up Procedure:

To use the TSH-P1 in place of VFK 1153, 'Post mechanical neutral plate', use the TSH-P1 plate only, without the 'plane height post' attached to the plate. Use the 'guide height bar' in place of VFK 1154 to visually determine the height of the tape guide posts. The width of the tape guide posts are slightly wider than the DVC tape width, matching very closely the full height of the Tentel guide height bar, as shown in Fig 2.

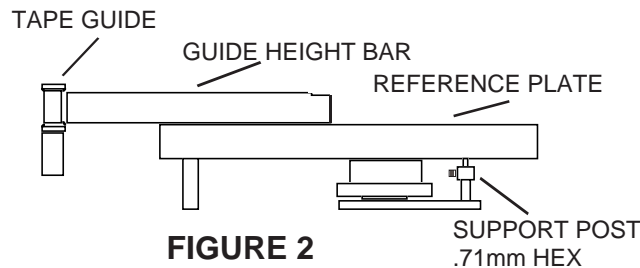

Plane set-up Procedure:

When using the TSH-P1 to replace VFK 1157, 'cassette mechanical neutral plate' the 'plane height post' should be attached to the TSH-P1 plate as shown in Fig. 3, using the 4 - 40x1/4" hex cap screw provided. The post then determines the proper 'plane' for adjustment of the cassette support post heights. These cassette support posts are attached to the reel table mechanism that slides 'back and forth' for various cassette sizes. Height adjustment is changed by using the .71 modified hex wrench to loosen and tighten the very small set screws on the 2 support posts. Support positions 'A', 'B', and the 'plane height post' determines the plane that cassette support posts at 'C' and 'D' should comply with. After adjustment of support heights at 'C' and 'D', remove the

'plane height post' from the reference plate. Use the reference plate to check for any rocking or out of flatness of the 4 support points; 'A', 'B', 'C', and 'D'. If rocking is detected, repeat the plane set up procedure, described above or in the factory service manual.

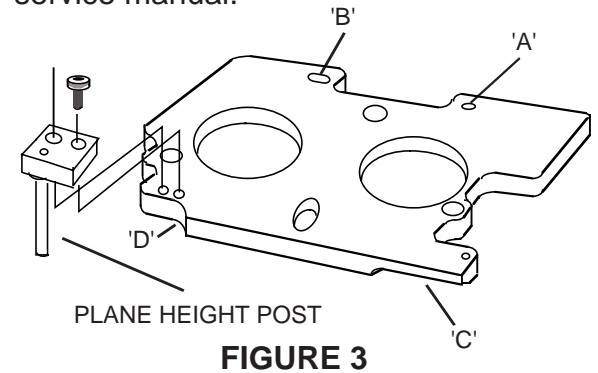

Reel table heights:

The Tentel TSH-P1 allows the reel table heights to be easily and accurately measured with the special dial indicator. Check that the indicator reads zero, using the wide flat side of the 'guide height bar' under the plate and indicator as shown in Fig.4.

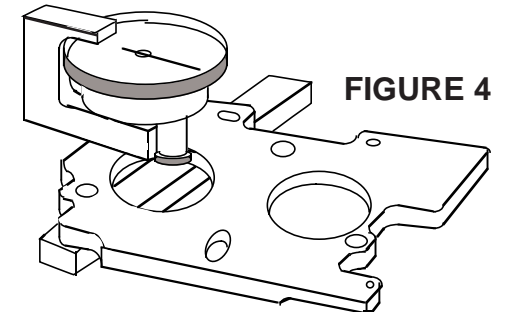

During measurement on the DVC transport make certain that the indicator probe is on the correct surface of the reel table as shown in Fig.5; the lower portion of the reel table. The correct specification for reel

LIMITED WARRANTY

The instructions and cautions in this manual should be thoroughly read and understood along with the related information in the 'factory' service manual. With proper care, handling and storage, the TENTEL TSH-P1 DVC reference plane gauge should provide years of trouble free, accurate readings. The TSH-P1 is guaranteed to be free of defects in materials and workmanship for a period of one year after receipt by the initial purchaser.

Note: This warranty does not cover damage caused by accident, abuse, alteration, disassembly, or failure to follow cautions and operating instructions. TENTEL assumes no responsibility or liability beyond the purchase price of the unit. The enclosed instructions and recommendations are intended as a helpful guide only, and TENTEL assumes no liability from damage by accident, misuse, or misapplication.

TENTEL

333 Industrial Drive #4

Placerville, CA 95667 U.S.A.

(530) 344-0183 / FAX 344-0186

www.tentel.com

(Ctd. from page 3) table height is:

REEL HEIGHT SPECIFICATION

Standards: 0.7 mm \pm .25mm

" Minimum .45 mm

" Maximum .95 mm

TENTEL RECOMMENDATION:

Minimum .60 mm

Maximum .75 mm

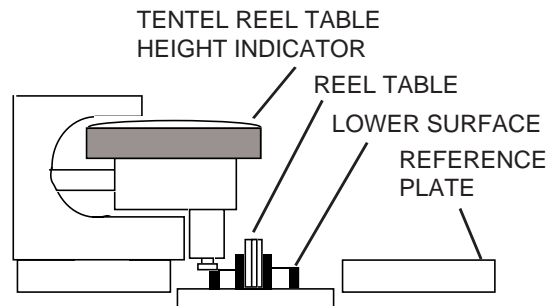

Figure 5

Reel table heights relate to the tape guide heights. These measurements are critical for their importance on proper tape handling while eliminating tape edge damage.

The perpendicularity of the reel tables can also be measured using the 'reel table height indicator'. By comparing height measurements at the 3:00, 6:00, 9:00, and 12:00 radial positions around the reel table, the desired $1/2^\circ$ ($30'$) of angle can be checked. The maximum and minimum of the 4 radial readings should be within .15mm of each other, to comply with the $1/2^\circ$ tolerance.

If this is your first, or one of your first pieces of TENTEL test instruments for the DVCPPro format, please ask for a list of the other powerful, accurate, time saving tools available from TENTEL. The replacement for the VFK1188 is extremely handy for proper, accurate set-up of the tension servo arm.

Our VFK 1155, 1156, and 1208 tension arm positioning fixtures are made to exacting tolerances and have a longer 'handle' for use without need for the tweezers.

The TQ-80-P dial torque gauge incorporates both required 'ranges' into one easy to use gauge. On some transports it's possible to make torque measurements without removal of the carriage assembly, since the long narrow end on the TQ-80-P fits down through the cut out above the reel tables.

TENTEL has a very handy, easy to follow printed procedure for placing the DVCPPro transport into the 'NO TAPE LOADING' mode for testing. This procedure is included with each mechanical 'package' or is available by contacting TENTEL.

Please feel free to contact TENTEL with any questions you may have regarding use of any of these test instruments.